

1. This guideline applies to:

- Wire Rod in coil loaded for export ferry crossings.

Note: The friction factor between coils and trailer decks determined as per EN 12195-1:2010 Annex B.1.2 is  $\mu=0.49$

2. Essential requirements

- All restraints must be webbing straps with minimum lashing capacity of 2000 daN compliant with EN 12195-2.
- All loads must be loaded or blocked against the trailer headboard.
- 2 small coils loaded side-by-side across the trailer to be treated as one.
- All coils securely banded with minimum of 4 evenly distributed steel bands.
- Triangular chocks must be used as shown on drawings to prevent coils rolling.



Warning: Unchocked coils may roll whilst loading and unloading. Use temporary chocks as necessary.

3. Overview of different strapping arrangements

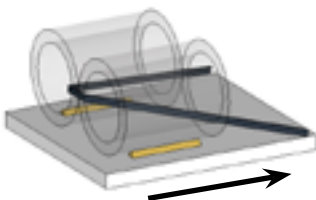

- ✓ Direct lashing through the bore of cross-loaded coils.
- ✓ Triangular chocks wedged on the outside of gunbarrel coils.

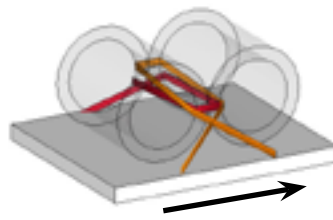

- ✓ 2 alpha-straps for each pair of cross-loaded coils.

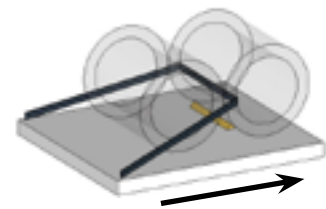

- ✓ Direct lashing through the bore of cross-loaded coils.
- ✓ Triangular chocks under each coil secured with a direct strap.

#### 4. Restraint system for XL rated trailers



Typical plaque on a trailer with a headboard and rear doors rated to EN 12642 Code XL.

##### 4.1 10 cross-loaded and 2 gunbarrel coils - XL rated trailer

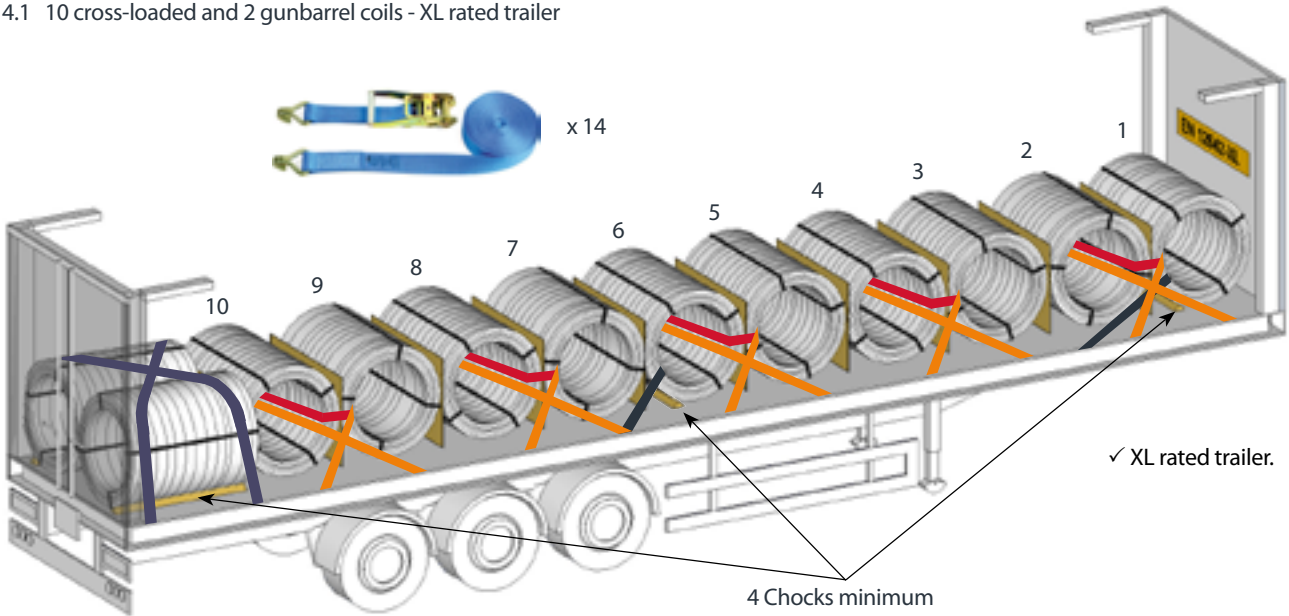

- ✓ Load to the headboard, and rear coils will be close to the rear doors.
- ✓ 2 over-the-top straps applied to the pair of gunbarrel coils at the rear.

- ✓ 2 direct lashings through the coils pulling back (coils 1 and 6).
- ✓ 2 alpha-straps for each pair of cross-loaded coils.
- ✓ Triangular chocks positioned as per drawing.

##### 4.2 11 cross-loaded coils - XL rated trailer

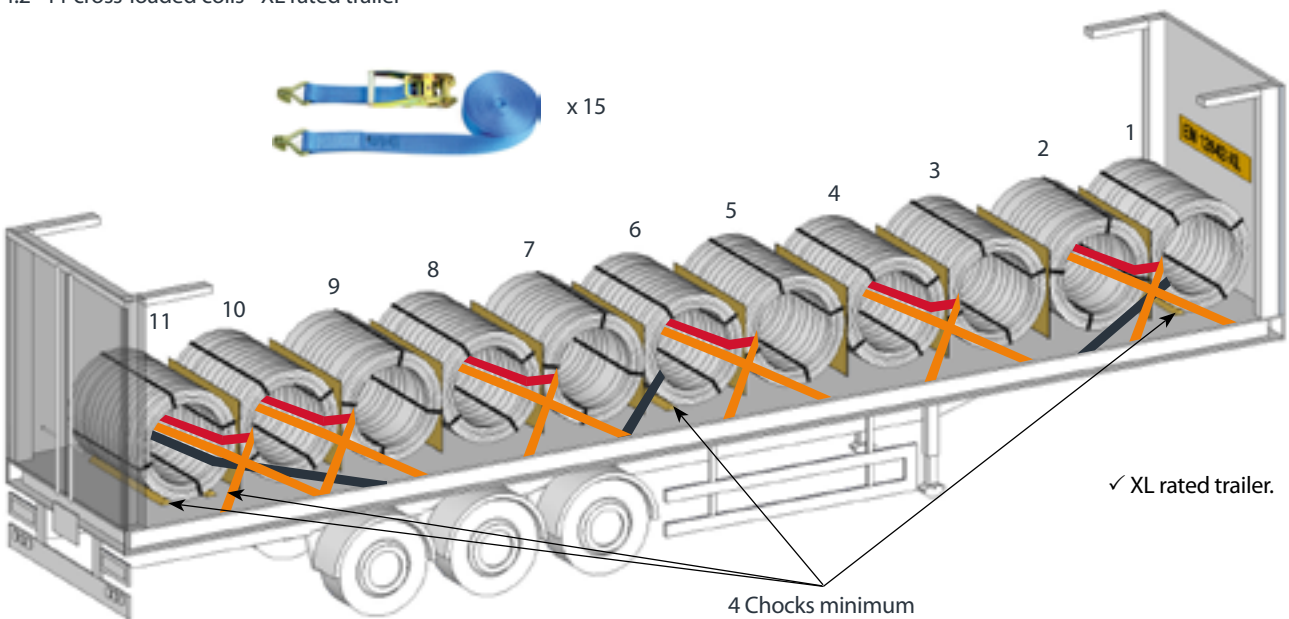

- ✓ 1 direct lashing through the rear coil pulling forwards.
- ✓ 2 alpha-straps for each pair of cross-loaded coils.

- ✓ 2 direct lashings through the coils pulling back (coils 1 and 6).
- ✓ Triangular chocks positioned as per drawing.



5. Restraint system for non XL rated trailers

5.1 10 cross-loaded and 2 gunbarrel coils - non XL rated trailer

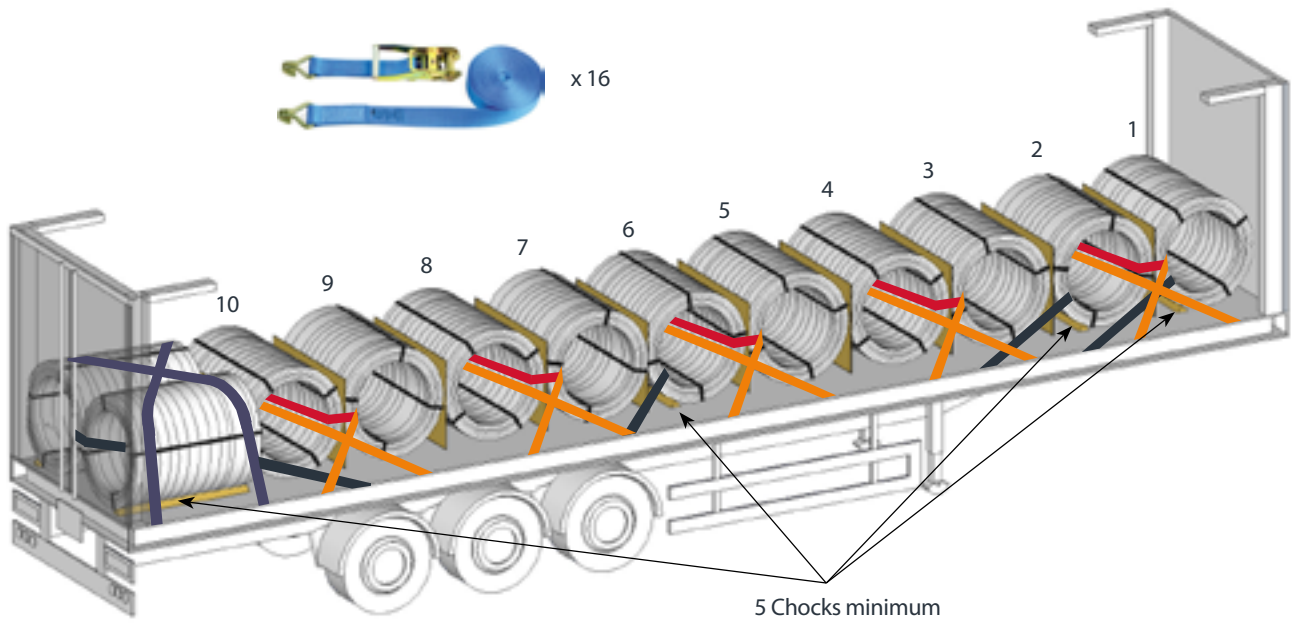

- ✓ 1 direct lashing through the pair of gunbarrel coils at the rear pulling forwards.
- ✓ 2 over-the-top straps applied to the pair of gunbarrel coils at the rear.

- ✓ 3 direct lashings through the front coils pulling back (coils 1, 2 and 6).
- ✓ 2 alpha-straps for each pair of cross-loaded coils.
- ✓ Triangular chocks positioned as per drawing.

5.2 11 cross-loaded coils - non XL rated trailer

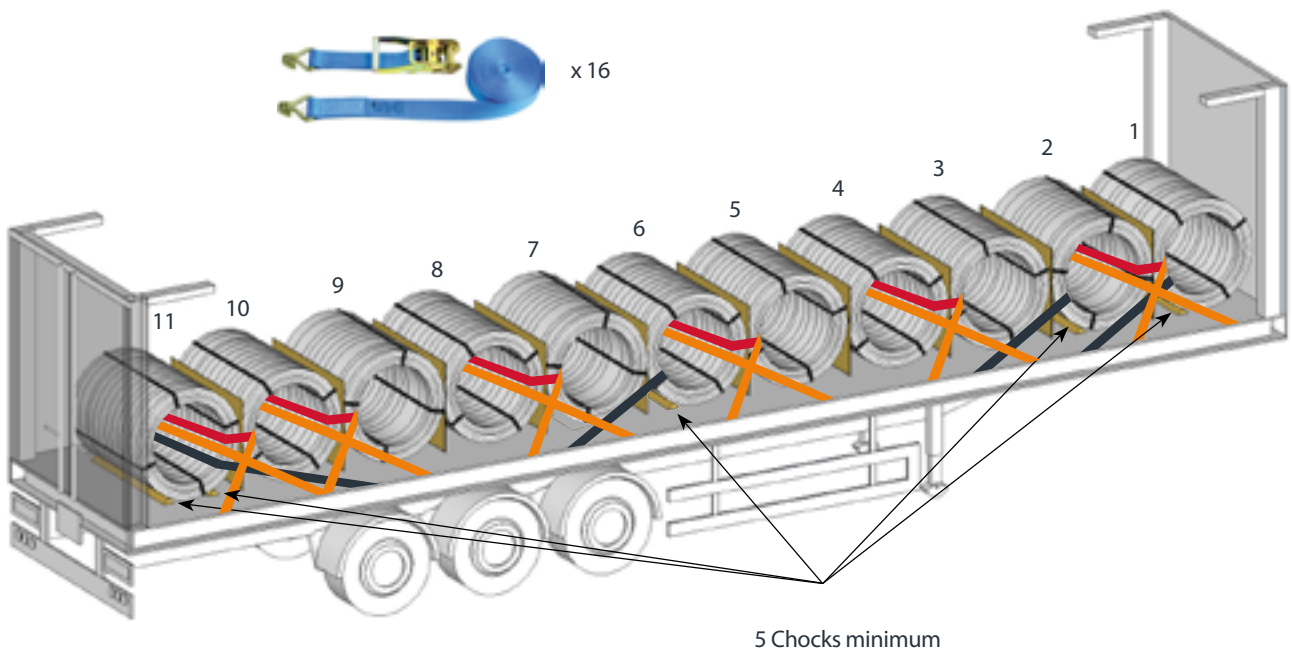

- ✓ 1 direct lashing through the rear coil pulling forwards (coil 11).
- ✓ 2 alpha-straps for each pair of cross-loaded coils.

- ✓ 3 direct lashings through the front coils pulling back (coils 1, 2 and 6).
- ✓ Triangular chocks positioned as per drawing.



6. Intermodal rail loads - MUST use XL rated trailers



Typical plaque on a trailer with a headboard and rear doors rated to EN 12642 Code XL.

6.1 10 cross-loaded and 2 gunbarrel coils - XL rated trailer

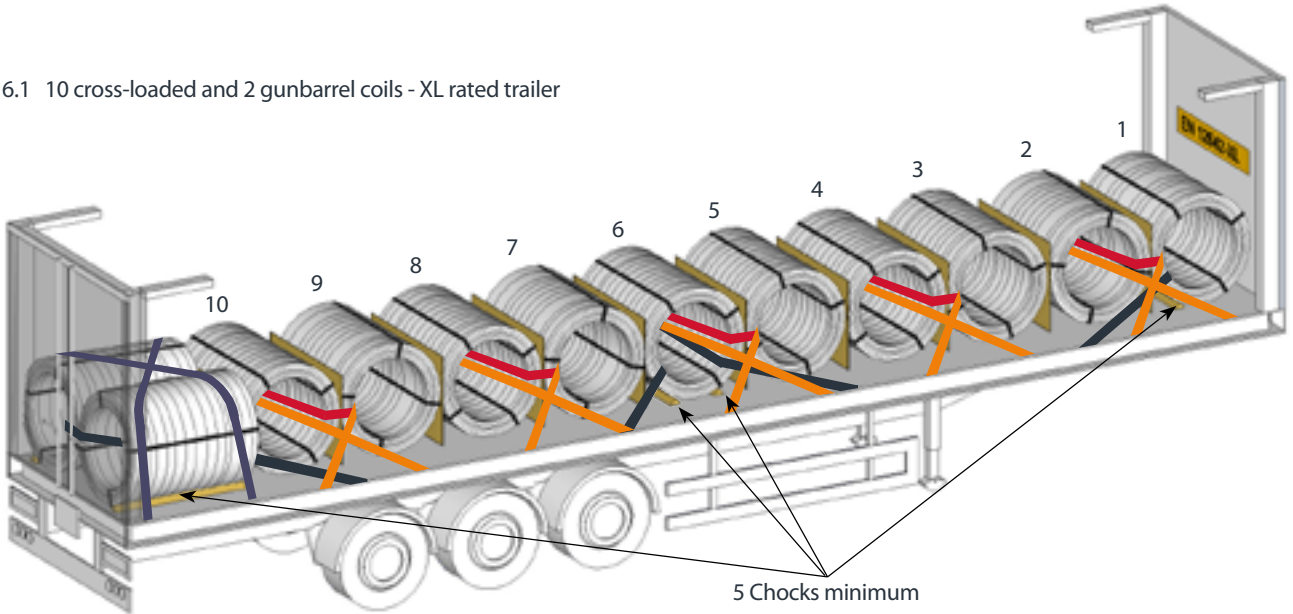

- ✓ 2 over-the-top straps applied to the pair of gunbarrel coils at the rear. Rear coils must be close to rear doors.
- ✓ 1 direct lashing through the pair of gunbarrel coils at the rear pulling forwards.
- ✓ 1 direct lashings through middle coil pulling forwards (coil 6).

- ✓ 2 direct lashings through the front coil pulling back (coils 1 and 6).
- ✓ 2 alpha-straps for each pair of cross-loaded coils.
- ✓ Triangular chocks positioned as per drawing.

6.2 11 cross-loaded coils - XL rated trailer

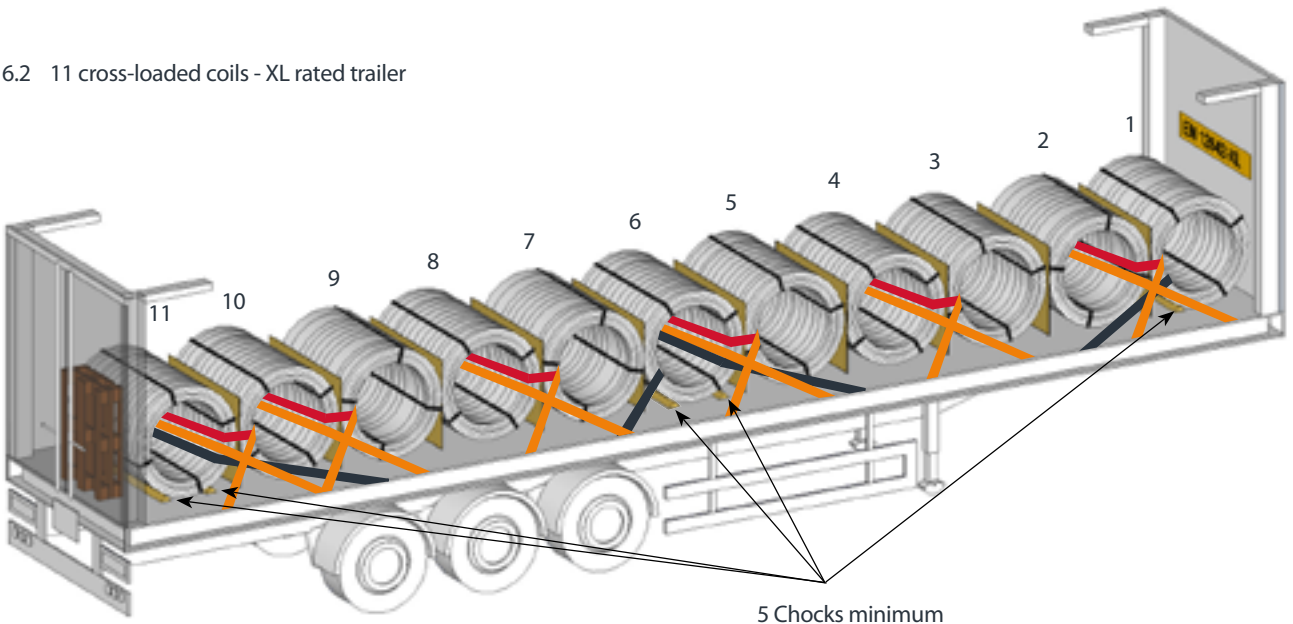

- ✓ 2 direct lashings through coils pulling forwards (coils 6 and 11).
- ✓ Block any gap between coils and rear doors.

- ✓ 2 direct lashings through the coils pulling back (coils 1 and 6).
- ✓ 2 alpha-straps for each pair of cross-loaded coils.
- ✓ Triangular chocks positioned as per drawing.

BRITISHSTEEL.CO.UK

A | PO Box 1, Brigg Road, Scunthorpe, North Lincolnshire, DN16 1BP  
 T | +44 (0)1724 402436 E | getintouch@longssteel.com

LRG-0019-WRIC Export Issue 1

Care has been taken to ensure that the contents of this publication are accurate, but British Steel UK Limited and its subsidiaries and associated undertakings (having the meaning set out in the Companies Act 2006) do not accept responsibility or liability for errors or information that is found to be misleading.

Copyright British Steel 2016

British Steel UK Limited is registered in England under number 09438207 with registered office at Administration Building, Brigg Road, Scunthorpe, DN16 1BP.

