

1. Introduction

This Technical Information Sheet defines the requirements for headboards on trailers used to transport British Steel products.

Headboards serve two vital functions:

- They can form an integral part of a load restraint system if the product is blocked directly against them.
- They can act as a safety back-up if the primary load restraint system fails.

2. Headboard height

Headboards on trailers used to transport British Steel products shall be high enough to prevent any part of the load from sliding over it.

3. Headboard strength

Headboards on trailers used to transport British Steel products shall be rated to one of the following capacities:

Table 1: Headboard rated capacities

Curtainsider	Flatbed/Slidaflex
EN 12642 Code L (5,000 daN)	5,000 daN
-	10,000 daN
EN 12642 Code XL (50% of max. payload*)	13,500 daN

Note: 1,000 daN is equal to approximately 1 tonne of force.

*Typical load capacity of 13,500 daN.

4. Testing and certification

Manufacturers shall test and certify headboard strength on all new trailers. Testing should be undertaken in accordance with EN 12642:2006 Securing of cargo on road vehicles - Body structure of commercial vehicles - Minimum requirements. Testing is to be carried out by applying a uniform load over the surface of the headboard across the full width and up to a height of either 1600 mm, or 3/4 of the height of the headboard if it is above 2130 mm high.

The strength of the headboard shall be stated on the trailer certificate and the trailer plaques. Curtainsiders, box type, and drop side bodies with side and tail boards manufactured to EN 12642 will have signage on either the headboard or the chassis frame. Examples of code XL rated trailer plaques and signage are shown below:

Geprüfte Aufbaufestigkeit / Confirmed bodystrength		
Vorderwand / Frontwall	0,5 P	13.500 daN
Seitenwand / Sidewall	0,4 P	10.800 daN
Rückwand / Rearwall	0,3 P	8.100 daN
P = 27.000 Kg		
Fahrzeug entspricht Vehicle body in compliance with		EN 12642-XL certificate
		



Examples of trailer plaques / signs stating frontwall (headboard) strength and /or compliance with EN 12642 - XL.

5. Flatbed trailers

There is currently limited application of EN 12642 to flatbed trailers and it is rare to see headboard strength stated on either the trailer certificate or the trailer itself. The following information is provided to allow some guidance on load bearing capacity of flatbed trailer headboards:

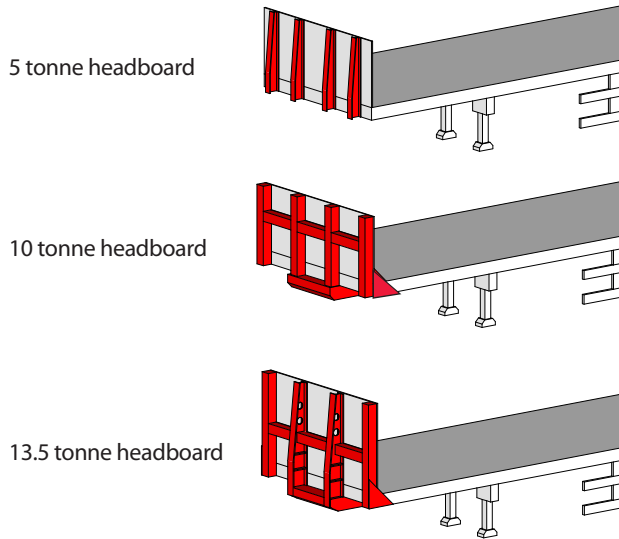

5 tonne capacity:

- 4 vertical supports welded securely to the chassis frame.
- Steel plate headboard.

10 tonne capacity:

- 4-off heavy duty vertical supports mounted on strengthened chassis framework.
- Corner bracing.
- Steel plate headboard with cross member.

13.5 tonne capacity:

- 4-off specially designed vertical supports mounted on strengthened chassis framework.
- Corner bracing.
- Steel plate headboard with cross member.

If in doubt refer to the trailer manufacturer or the Tata Steel Load Restraint Engineers.

Bracing of headboards

Lashing a headboard back with restraints can significantly increase its load bearing capacity.

Example: Bracing a 750 mm high headboard with an 8 mm transport chain can increase the load bearing capacity of a 5 tonne headboard up to 10 tonnes.

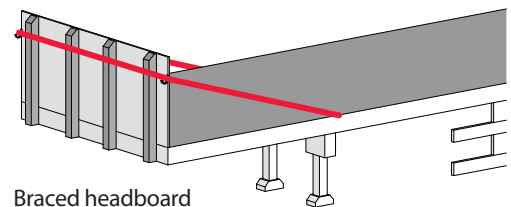

6. Loading to headboards

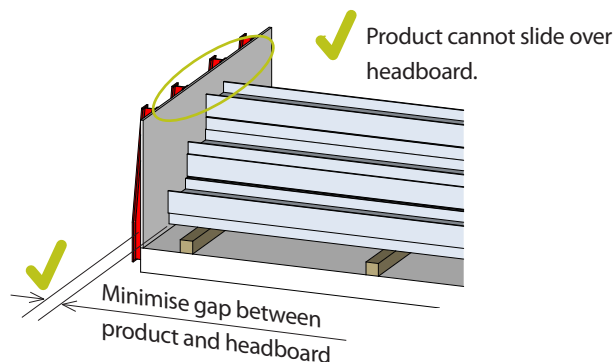

- All British Steel products shall be loaded below the height of the trailer headboard unless they are physically blocked by another method.
- If the trailer headboard is an integral part of the load restraint system then the product must be loaded as close to the headboard as possible.
- Timbers may be stacked and secured between the product and the headboard in order to prevent damage to the headboard.

7. Condition and inspection

Trailer headboards should be inspected on a regular basis as part of routine maintenance checks and as part of the driver inspections at time of use. Defects to look for include:

- Cracked welds
- Severe corrosion
- Bent uprights
- Badly damaged face plates
- Twisting of trailer front beam



BRITISHSTEEL.CO.UK

A | PO Box 1, Brigg Road, Scunthorpe, North Lincolnshire, DN16 1BP
E | getintouch@longsteel.com

TIS-0010 Issue 1

Care has been taken to ensure that the contents of this publication are accurate, but British Steel UK Limited and its subsidiaries and associated undertakings (having the meaning set out in the Companies Act 2006) do not accept responsibility or liability for errors or information that is found to be misleading.

Copyright British Steel 2016

British Steel UK Limited is registered in England under number 09438207 with registered office at Administration Building, Brigg Road, Scunthorpe, DN16 1BP.

